

DIES ROLLERI TYPE R3

Content Explanation	136 - 137
Dies 90°, H=55 (2.17)	138
Dies 88°, H=55 (2.17)	139
Dies 85°, H=55 (2.17)	139
Dies 80°, H=65 (2.56) / H=85 (3.35)	140
Dies 60°, H=55 (2.17) / H=65 (2.56)	140
Dies 30°, H=55 (2.17) / H=60 (2.36)	141
Dies 30°, H=70 (2.76)	142
Dies, H=100 (3.94) / H=120 (4.72) / H=150 (5.91)	143 - 145
Hemming Dies	146
Synthetic Dies, H=100 (3.94)	147
Die Adapters	147

Compatibility

Dies Roller Type R3 are compatible with press brake machines from:

- Bystronic-Beyeler RFA
- Bystronic-Beyeler RF
- Bystronic-Beyeler R
- Bystronic-Beyeler S

With Adapter-Systems the dies Roller Type R3 are also applicable on all other press brake machines.



Compatibility

Dies Rolleri Type R3 are:

- **compatible** with press brake machines with a table groove for pins 13 x 20 mm: Bystronic-Beyeler, Bystronic-Hämmerle, Safan, SMD, Trumpf
- also applicable on all other press brake machines **with Adapter-Systems and Adapter Rails** (see pages 218-221).

Material

The raw material is obtained from qualified suppliers which compose the chemical formulas according to international standards. Therefore, guaranteeing high resilience and tensile strength.

Material Type	Mechanical resistance of the material and the tool body	Hardness of the material and the tool body	Hardness of the operating surfaces after induction hardening
42CrMo4	900-1150 N/mm ²	29.1 - 36.9 HRC	54 - 60 HRC
C45	560-710 N/mm ²	12 - 15.5 HRC	54 - 60 HRC

- Specifications for the maximum press force kN/m are indicated as such, **1 t = 10 kN**.

Tang

All dies Rolleri Type R3 are by default equipped with a **13 x 20 mm (0.51 x 0.79 in) tail**.

Indications of precision ground surfaces:

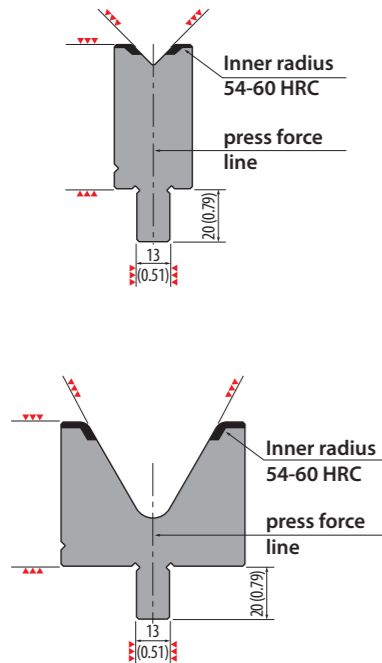

Our Advantages – Your Convenience

- own production facilities (no reseller or dealer)
- tracking of every tool possible, with a unique **serial number** on every article after the quality control check
- precision grinding (tolerance of +/-0.01 mm)
- guaranteed tool reproduction
- exact parallelism
- precise, consistent working height
- modifications possible (see pages 250-253)
- very large stock availability

Modification: Wedge Bar / Tail

In order to also use Rolleri Type R1 Dies, a 10 mm (0.39 in) groove is milled and a percise grounded wedge bar / tail in 13 x 30 mm (0.51 x 1.18 in) is inserted.

For more specific information and prices go to page 252 in the Service Chapter.

Example of Application

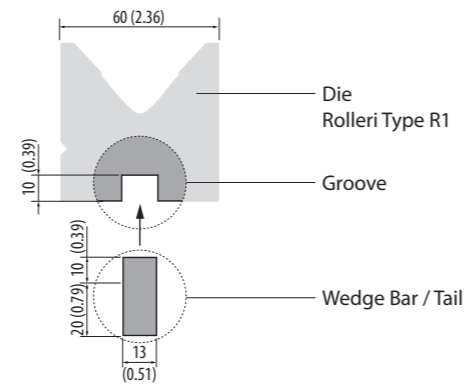

Tool lengths and sectioning

Standard

1000 mm (39.37 in)

500 mm (19.68 in)

525 mm (20.67 in)

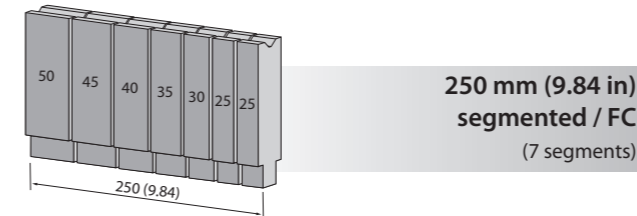
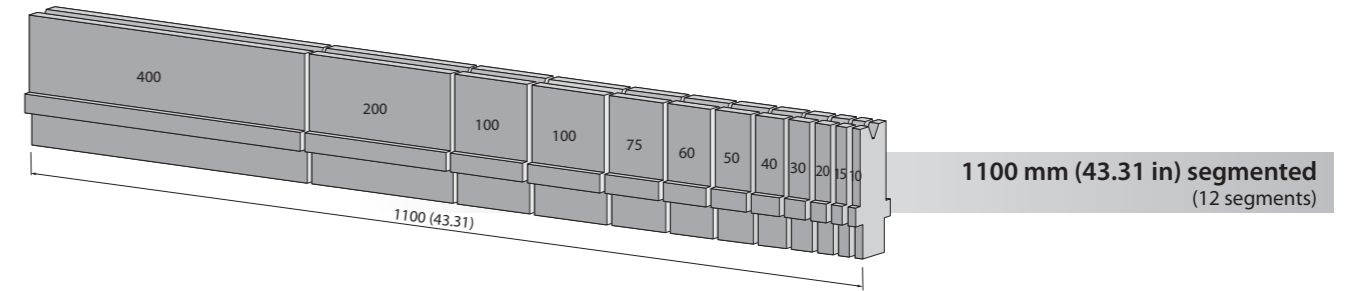

Segmented tools are delivered in complete sets. Single pieces are also available! More lengths and sectionings are possible upon request.



R3 ROLLERI TYPE R3

Dies 90°, H=55 (2.17)

BMR55.06.90

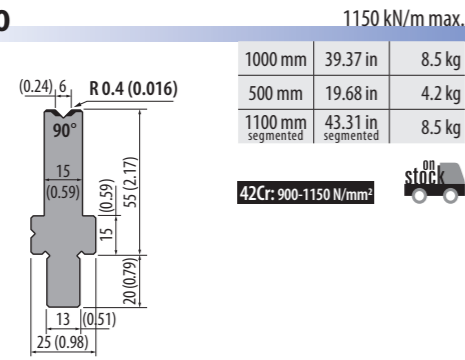

BMR55.08.90

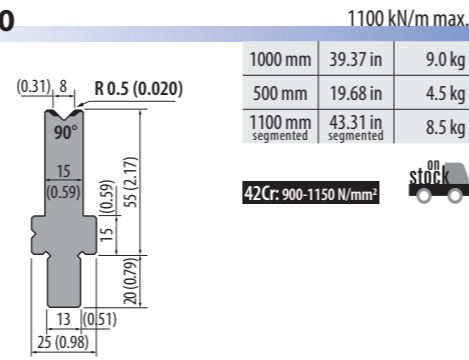

BMR55.10.90

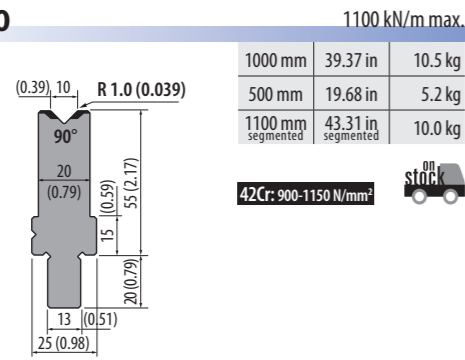

BMR55.12.90

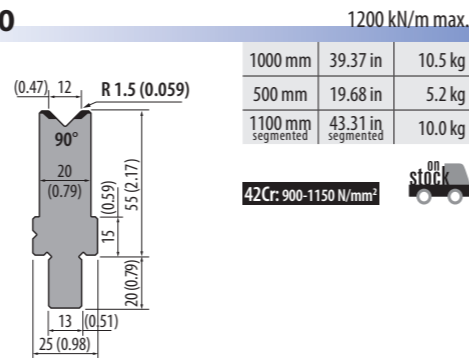

BMR55.16.90

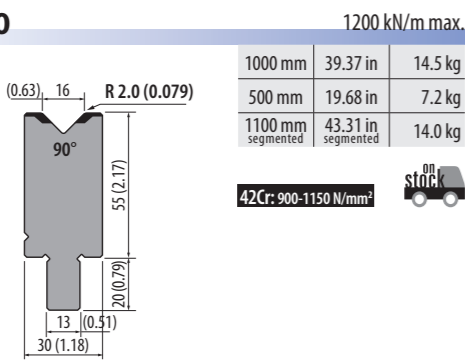

R3 ROLLERI TYPE R3

Dies 88°, H=55 (2.17)



BMR55.10.88

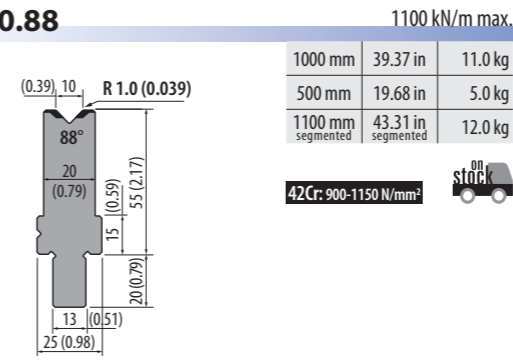

BMR55.12.88

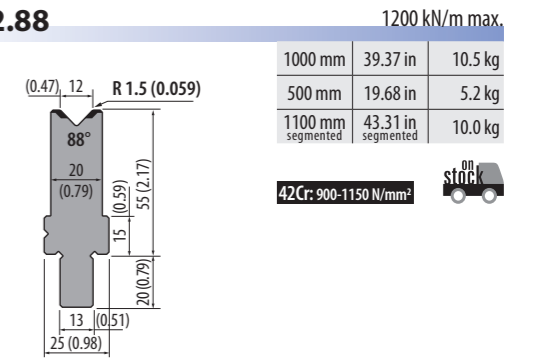

BMR55.16.88

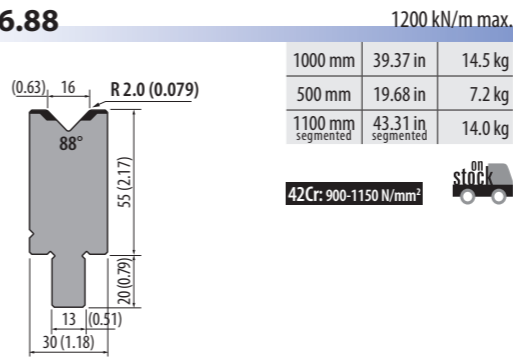

BMR55.20.88

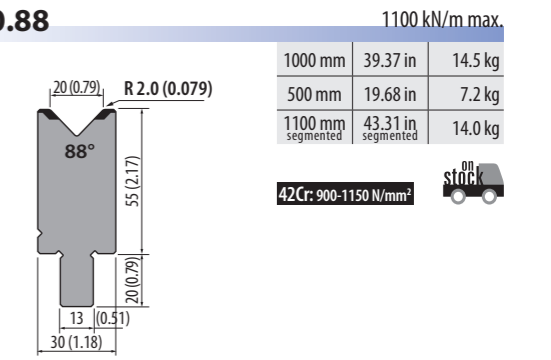

BMR55.24.88

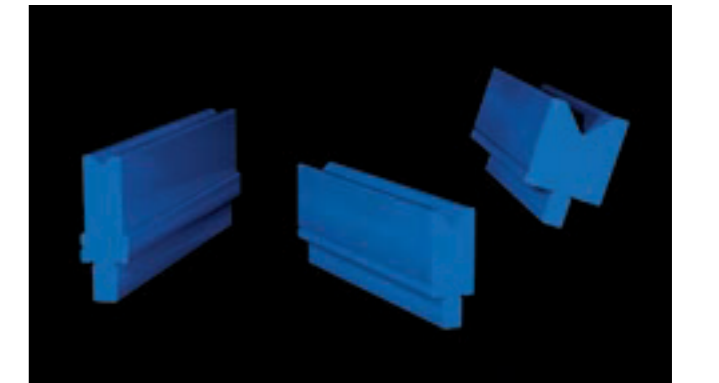
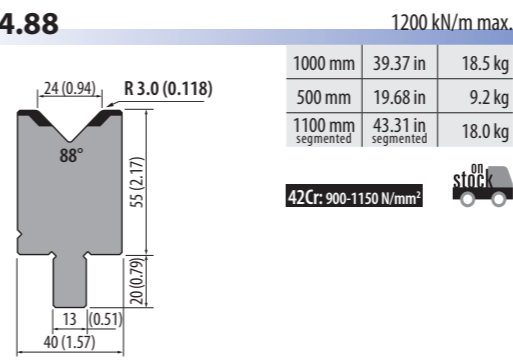

Dies 85°, H=55 (2.17)

BMR55.32.85

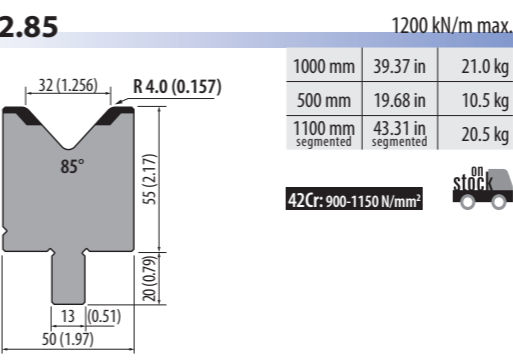

BMR55.40.85

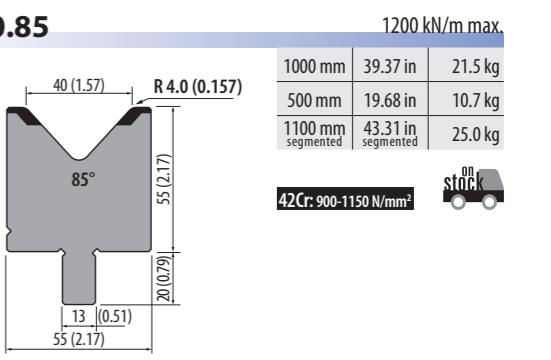

R3 ROLLERI TYPE R3

Dies 80°, H=65 (2.56) / H=85 (3.35)

BMR65.80.80

1700 kN/m max.

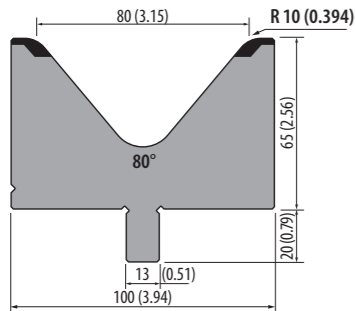

1000 mm	39.37 in	39.0 kg
500 mm	19.68 in	20.0 kg
1100 mm segmented	43.31 in segmented	43.0 kg

42Cr: 900-1150 N/mm²



BMR85.100.80

2300 kN/m max.

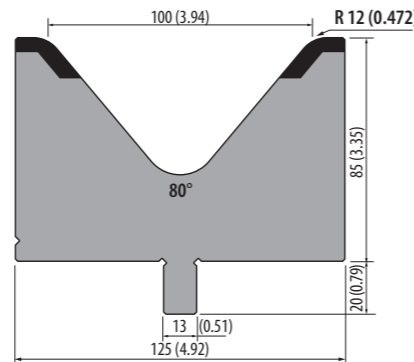

1000 mm	39.37 in	62.0 kg
500 mm	19.68 in	31.0 kg
1100 mm segmented	43.31 in segmented	69.0 kg

42Cr: 900-1150 N/mm²



R3 ROLLERI TYPE R3

Dies 30°, H=55 (2.17), H=60 (2.36)



BMR55.06.30

350 kN/m max.

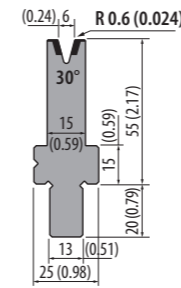

1000 mm	39.37 in	8.0 kg
500 mm	19.68 in	4.0 kg
1100 mm segmented	43.31 in segmented	9.0 kg

42Cr: 900-1150 N/mm²



BMR55.08.30

200 kN/m max.

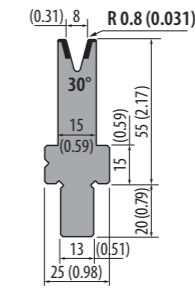

1000 mm	39.37 in	9.2 kg
500 mm	19.68 in	4.0 kg
1100 mm segmented	43.31 in segmented	10.1 kg

42Cr: 900-1150 N/mm²



BMR55.10.30

350 kN/m max.

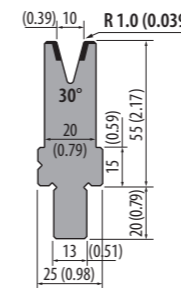

1000 mm	39.37 in	10.0 kg
500 mm	19.68 in	5.0 kg
1100 mm segmented	43.31 in segmented	11.0 kg

42Cr: 900-1150 N/mm²



BMR55.12.30

300 kN/m max.

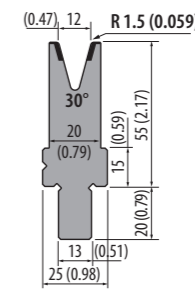

1000 mm	39.37 in	10.0 kg
500 mm	19.68 in	5.0 kg
1100 mm segmented	43.31 in segmented	11.0 kg

42Cr: 900-1150 N/mm²



Dies 60°, H=55 (2.17), H=65 (2.56)

BMR55.40.60

1300 kN/m max.

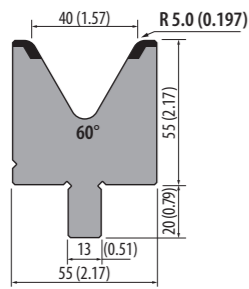

1000 mm	39.37 in	20.3 kg
500 mm	19.68 in	10.5 kg
1100 mm segmented	43.31 in segmented	22.3 kg

42Cr: 900-1150 N/mm²



BMR55.50.60

1200 kN/m max.

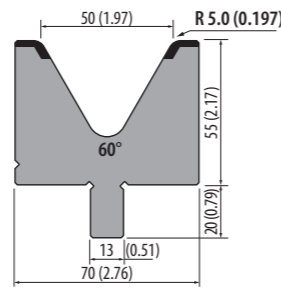

1000 mm	39.37 in	25.0 kg
500 mm	19.68 in	12.0 kg
1100 mm segmented	43.31 in segmented	21.0 kg

42Cr: 900-1150 N/mm²



BMR55.16.30

450 kN/m max.

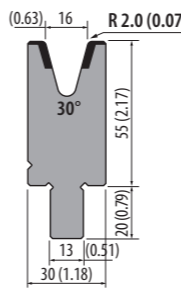

1000 mm	39.37 in	13.5 kg
500 mm	19.68 in	6.7 kg
1100 mm segmented	43.31 in segmented	14.9 kg

42Cr: 900-1150 N/mm²



BMR55.20.30

500 kN/m max.

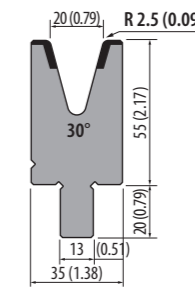

1000 mm	39.37 in	14.0 kg
500 mm	19.68 in	7.0 kg
1100 mm segmented	43.31 in segmented	13.5 kg

42Cr: 900-1150 N/mm²



BMR65.60.60

1100 kN/m max.

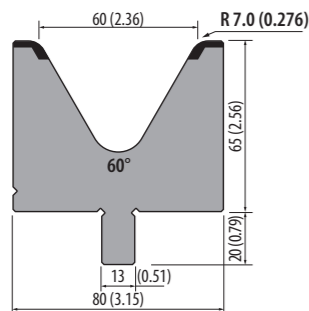

1000 mm	39.37 in	31.0 kg
500 mm	19.68 in	15.5 kg
1100 mm segmented	43.31 in segmented	34.1 kg

42Cr: 900-1150 N/mm²



BMR55.24.30

550 kN/m max.

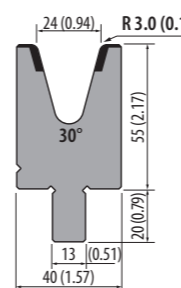

1000 mm	39.37 in	15.5 kg
500 mm	19.68 in	7.8 kg
1100 mm segmented	43.31 in segmented	17.0 kg

42Cr: 900-1150 N/mm²



BMR60.32.30

650 kN/m max.

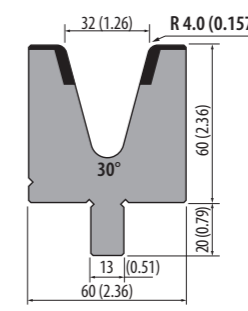

1000 mm	39.37 in	23.0 kg
500 mm	19.68 in	11.5 kg
1100 mm segmented	43.31 in segmented	22.5 kg

42Cr: 900-1150 N/mm²



BMR70.08.30

200 kN/m max.

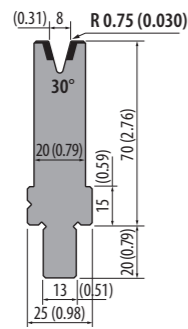

1000 mm	39.37 in	13.1 kg
500 mm	19.68 in	6.5 kg
1100 mm segmented	43.31 in segmented	14.0 kg

42Cr: 900-1150 N/mm²



BMR70.10.30

350 kN/m max.

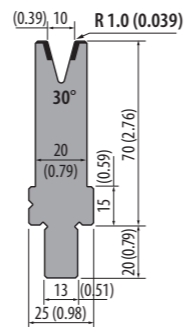

1000 mm	39.37 in	12.8 kg
500 mm	19.68 in	6.4 kg
1100 mm segmented	43.31 in segmented	12.4 kg

42Cr: 900-1150 N/mm²



BMR70.12.30

300 kN/m max.

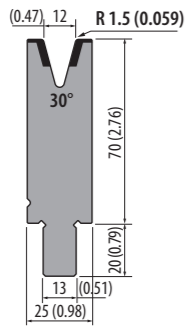

1000 mm	39.37 in	14.7 kg
500 mm	19.68 in	7.3 kg
1100 mm segmented	43.31 in segmented	14.3 kg

42Cr: 900-1150 N/mm²



BMR70.16.30

450 kN/m max.

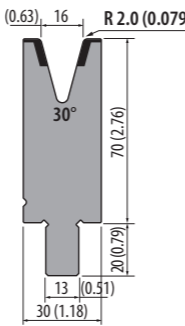

1000 mm	39.37 in	16.7 kg
500 mm	19.68 in	8.3 kg
1100 mm segmented	43.31 in segmented	16.2 kg

42Cr: 900-1150 N/mm²



86° Dies, H=100 (3.94)

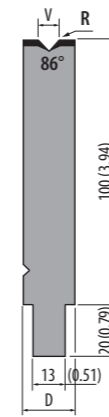

Individual drawings, available lengths and prices see pages 101-103



42Cr: 900-1150 N/mm²

Model	V (mm)	V (in)	R (mm)	R (in)	D (mm)	D (in)	kN/m max.
TMR100.04.86	4	0.16	0.6	0.02	20	0.79	450
TMR100.06.86	6	0.24	0.6	0.02	20	0.79	1200
TMR100.08.86	8	0.31	0.8	0.03	20	0.79	1150
WMR100.08.86	8	0.31	2.5	0.10	25	0.98	400
TMR100.10.86	10	0.39	1.0	0.04	20	0.79	1100
TMR100.12.86	12	0.47	1.0	0.04	25	0.98	1200
WMR100.12.86	12	0.47	2.5	0.10	25	0.98	500
TMR100.16.86	16	0.63	1.6	0.06	30	1.18	1200
TMR100.20.86	20	0.79	2.0	0.08	30	1.18	1150
TMR100.24.86	24	0.94	2.5	0.10	35	1.38	1200
TMR100.30.86	30	1.18	3.0	0.12	45	1.77	1200
TMR100.40.86	40	1.57	3.0	0.12	55	2.17	1200
TMR100.50.86	50	1.97	3.0	0.12	75	2.95	1500

84° Dies, H=100 (3.94)

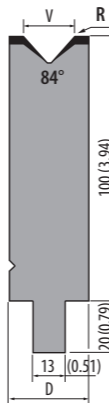

Individual drawings, available lengths and prices see pages 103-104

42Cr: 900-1150 N/mm²



Model	V (mm)	V (in)	R (mm)	R (in)	D (mm)	D (in)	kN/m max.
TMR100.06.84	6	0.24	0.6	0.02	20	0.79	1200
TMR100.08.84	8	0.31	0.8	0.03	20	0.79	1150
TMR100.10.84	10	0.39	1.0	0.04	20	0.79	1100
TMR100.12.84	12	0.47	1.0	0.04	25	0.98	1200
TMR100.16.84	16	0.63	1.6	0.06	30	1.18	1200
TMR100.20.84	20	0.79	2.0	0.08	30	1.18	1150
TMR100.24.84	24	0.94	2.5	0.10	35	1.38	1200

80° Dies, H=100 (3.94) / H=120 (4.72)

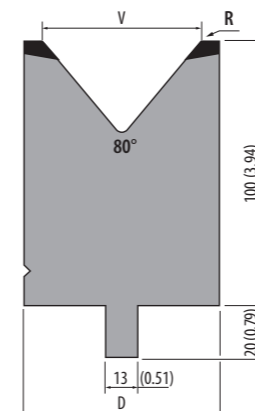

Individual drawings, available lengths and prices see page 105

42Cr: 900-1150 N/mm²



Model	V (mm)	V (in)	H (mm)	H (in)	R (mm)	R (in)	D (mm)	D (in)	kN/m max.
TMR100.60.80	60	2.36	100	3.94	5.0	0.20	75	2.95	1500
TMR100.70.80	70	2.76	100	3.94	5.0	0.20	85	3.35	1500
TMR100.80.80	80	3.15	100	3.94	5.0	0.20	100	3.94	1500
TMR120.90.80	90	3.54	120	4.72	8.0	0.31	110	4.33	1500
TMR120.100.80	100	3.94	120	4.72	8.0	0.31	120	4.72	1500

60° Die, H=120 (4.72)

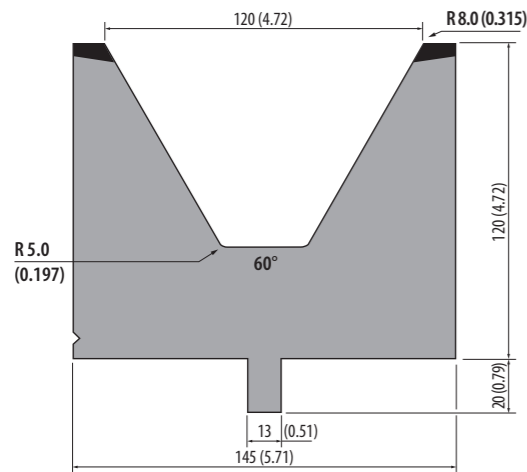

Individual drawings, available lengths and prices see page 106

Model	V (mm)	V (in)	R (mm)	R (in)	D (mm)	D (in)	kN/m max.
TMR120.120.60	120	4.72	8.0	0.31	145	5.71	1000

42Cr: 900-1150 N/mm²

84° Dies, H=150 (5.91)

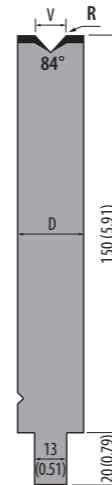

Individual drawings, available lengths and prices see pages 110-111

Model	V (mm)	V (in)	R (mm)	R (in)	D (mm)	D (in)	kN/m max.
TMR150.06.84	6	0.24	0.6	0.02	20	0.79	400
TMR150.08.84	8	0.31	0.8	0.03	20	0.79	400
TMR150.10.84	10	0.39	1.0	0.04	20	0.79	500
TMR150.12.84	12	0.47	1.0	0.04	25	0.98	500
TMR150.16.84	16	0.63	1.6	0.06	30	1.18	700
TMR150.20.84	20	0.79	2.0	0.08	30	1.18	700
TMR150.24.84	24	0.94	2.5	0.10	35	1.38	700

42Cr: 900-1150 N/mm²

30° Dies, H=100 (3.94)

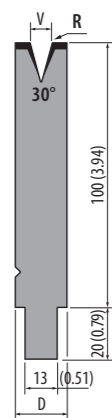

Individual drawings, available lengths and prices see pages 106-108

Model	V (mm)	V (in)	R (mm)	R (in)	D (mm)	D (in)	kN/m max.
TMR100.04.30	4	0.16	0.6	0.02	20	0.79	150
TMR100.06.30	6	0.24	0.6	0.02	20	0.79	400
WMR100.06.30	6	0.24	2.0	0.08	20	0.79	400
TMR100.08.30	8	0.31	1.0	0.04	20	0.79	400
WMR100.08.30	8	0.31	2.5	0.10	20	0.79	400
TMR100.10.30	10	0.39	1.0	0.04	20	0.79	400
WMR100.10.30	10	0.39	2.5	0.10	25	0.98	400
TMR100.12.30	12	0.47	1.0	0.04	25	0.98	400
WMR100.12.30	12	0.47	3.0	0.12	25	0.98	400
TMR100.16.30	16	0.63	1.6	0.06	30	1.18	500
TMR100.20.30	20	0.79	2.0	0.08	30	1.18	600
TMR100.24.30	24	0.94	2.5	0.10	40	1.57	650
TMR100.30.30	30	1.18	3.0	0.12	55	2.17	900
TMR100.40.30	40	1.57	5.0	0.20	60	2.36	900

42Cr: 900-1150 N/mm²

80° Dies, H=150 (5.91)

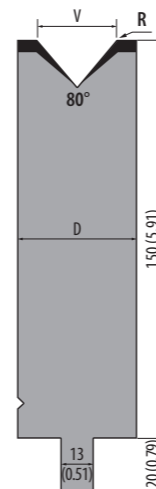

Individual drawings, available lengths and prices see page 112

Model	V (mm)	V (in)	R (mm)	R (in)	D (mm)	D (in)	kN/m max.
TMR150.24.80	24	0.94	2.5	0.10	35	1.38	700
TMR150.30.80	30	1.18	5.0	0.20	45	1.77	900
TMR150.40.80	40	1.57	5.0	0.20	55	2.17	1200
TMR150.50.80	50	1.97	5.0	0.20	65	2.56	1500

42Cr: 900-1150 N/mm²

86° Dies, H=150 (5.91)

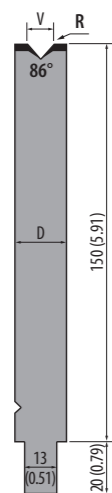

Individual drawings, available lengths and prices see pages 109-110

Model	V (mm)	V (in)	R (mm)	R (in)	D (mm)	D (in)	kN/m max.
TMR150.06.86	6	0.24	0.6	0.02	20	0.79	400
TMR150.08.86	8	0.31	0.8	0.03	20	0.79	400
TMR150.10.86	10	0.39	1.0	0.04	20	0.79	500
TMR150.12.86	12	0.47	1.0	0.04	25	0.98	500
TMR150.16.86	16	0.63	1.6	0.06	30	1.18	700
TMR150.20.86	20	0.79	2.0	0.08	30	1.18	700
TMR150.24.86	24	0.94	2.5	0.10	35	1.38	700

42Cr: 900-1150 N/mm²

30° Dies, H=150 (5.91)

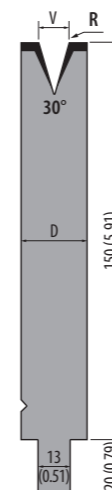

Individual drawings, available lengths and prices see pages 113-114

Model	V (mm)	V (in)	R (mm)	R (in)	D (mm)	D (in)	kN/m max.
TMR150.06.30	6	0.24	0.6	0.02	20	0.79	400
TMR150.08.30	8	0.31	1.0	0.04	20	0.79	400
TMR150.10.30	10	0.39	1.0	0.04	20	0.79	400
TMR150.12.30	12	0.47	1.0	0.04	25	0.98	400
TMR150.16.30	16	0.63	1.6	0.06	30	1.18	500
TMR150.20.30	20	0.79	2.0	0.08	35	1.38	600
TMR150.24.30	24	0.94	2.5	0.10	40	1.57	650
TMR150.30.30	30	1.18	3.0	0.12	55	2.17	900
TMR150.40.30	40	1.57	5.0	0.20	55	2.17	900

42Cr: 900-1150 N/mm²

BPR.SM.195.28.6

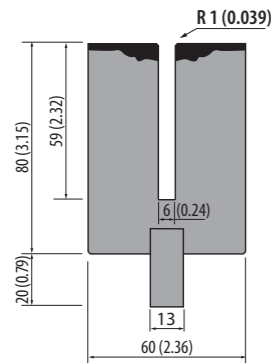

525 mm	20.67 in	12.0 kg
495 mm segmented	19.49 in segmented	11.0 kg

42Cr: 900-1150 N/mm²



Only for thin material!
Hemming punches
see page 126

BPR.SM.195.28.8

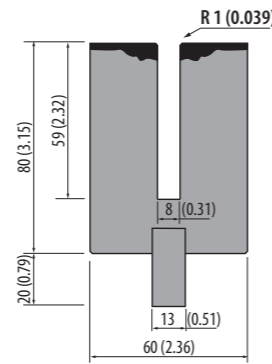

525 mm	20.67 in	12.0 kg
495 mm segmented	19.49 in segmented	11.0 kg

42Cr: 900-1150 N/mm²



BPR.SM.195.24.10

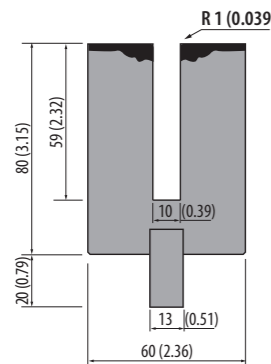

525 mm	20.67 in	11.8 kg
495 mm segmented	19.49 in segmented	11.2 kg

42Cr: 900-1150 N/mm²



BPR.SM.195.24.12

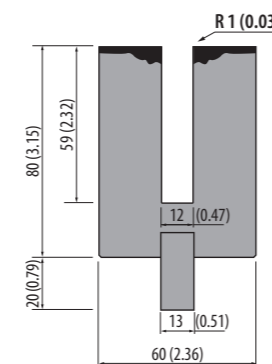

525 mm	20.67 in	11.5 kg
495 mm segmented	19.49 in segmented	10.8 kg

42Cr: 900-1150 N/mm²



Example of Application

S	S	A	A	R.45	R.70	S	S	A	A	R.45	R.70
mm	in	mm	in	Kgf/mm ²	Kgf/mm ²	mm	in	mm	in	Kgf/mm ²	Kgf/mm ²
0.6	0.02	3.0	0.12	9	15	0.6	0.02	1.2	0.05	23	35
0.8	0.03	3.0	0.12	12	20	0.8	0.03	1.6	0.06	32	50
1.0	0.04	3.5	0.14	15	25	1.0	0.04	1.0	0.04	40	60
1.25	0.05	3.5	0.14	17	26	1.25	0.05	2.5	0.10	50	80

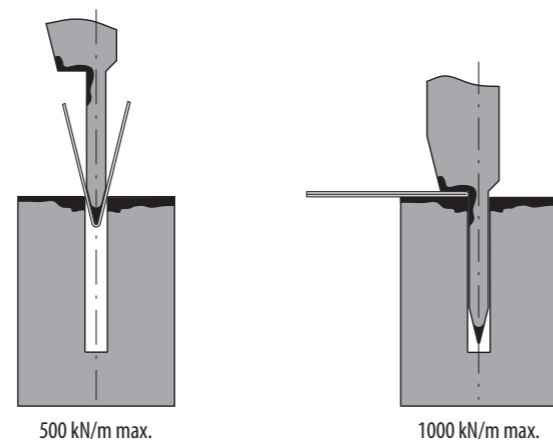

Our Advantages – Your Convenience

- easy handling
- faster and easier exchange
- preventing bending marks
- decrease of post-processing of bended profiles
- no contact of materials
- higher product quality

Mounting example

Synthetic dies will be adjusted into the housing and secured with bolted screws.

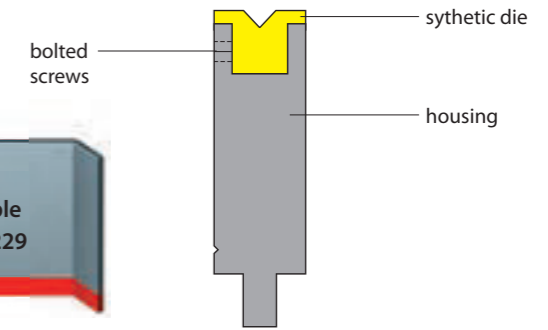

More mark-free bending available
see pages 222-229

TMN95.20

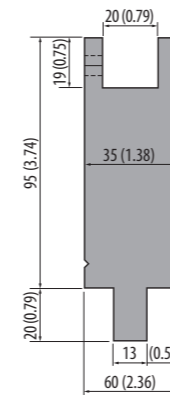

1000 kN/m max.		
835 mm	32.87 in	12.0 kg
415 mm	16.34 in	6.0 kg

C45: 560-710 N/mm²



INS20...

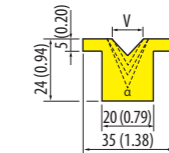

200 kN/m max.		
835 mm	32.87 in	0.40 kg
415 mm	16.34 in	0.20 kg



Model	α	V (mm)	V (in)
INS20.06.88	88°	6	0.24
INS20.08.88	88°	8	0.31
INS20.10.88	88°	10	0.39
INS20.12.88	88°	12	0.47
INS20.16.88	88°	16	0.63
INS20.06.60	60°	6	0.24
INS20.08.60	60°	8	0.31
INS20.10.60	60°	10	0.39
INS20.12.60	60°	12	0.47
INS20.16.60	60°	16	0.63

Model	α	V (mm)	V (in)
INS20.06.45	45°	6	0.24
INS20.08.45	45°	8	0.31
INS20.10.45	45°	10	0.39
INS20.12.45	45°	12	0.47
INS20.06.30	30°	6	0.24
INS20.08.30	30°	8	0.31
INS20.10.30	30°	10	0.39

Die Adapters

AD6

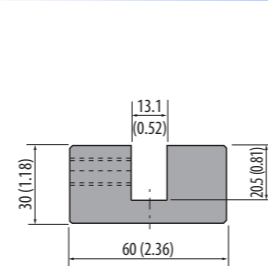

1000 kN/m max.		
1000 mm	39.37 in	12.0 kg
500 mm	19.68 in	6.0 kg

Rolleri Type R1
→ Rolleri Type R2/R3

C45: 560-710 N/mm²



AD5

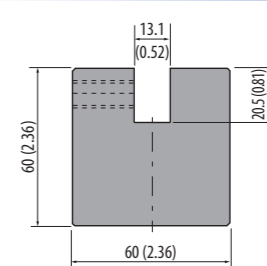

1000 kN/m max.		
1000 mm	39.37 in	26.1 kg
500 mm	19.68 in	13.0 kg

Rolleri Type R1
→ Rolleri Type R2/R3

C45: 560-710 N/mm²



AD8-12.7

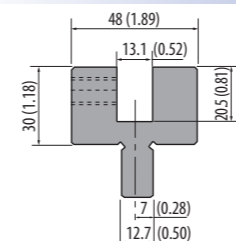

1000 kN/m max.		
1000 mm	39.37 in	15.0 kg
500 mm	19.68 in	7.5 kg

Rolleri Type RX LVD
→ Rolleri Type R2/R3

C45: 560-710 N/mm²



AD7

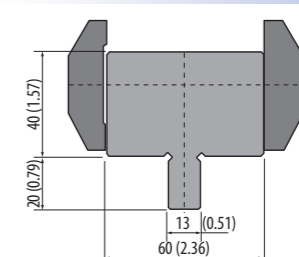

1000 kN/m max.		
835 mm	32.87 in	18.0 kg
415 mm	16.34 in	9.0 kg

Rolleri Type R2/R3
→ Rolleri Type R1

C45: 560-710 N/mm²

